

# MED Series

mechanical edge of dock

I.V.

## DOCK - RAMP

Operator friendly with no lifting involved.....  
.....simple, easy "pull-push" operation.

### Features

- Deck and lip operation assisted by balanced spring lifting system
- Smooth top plate transition
- Comfort grip operating handle
- Lifting hole in lip allows for quick and easy handling by installer

### Structural integrity

- Deck and lip plates made of premium grade 50,000 psi minimum yield diamond tread plate
- Heavy-duty 3/8" x 6" back beam
- One-piece, continuous front and rear hinge pins for enhanced strength and durability
- Lip bevel helps protect material handling equipment steering systems and cargo
- Two (2) molded rubber bumpers bolted onto heavy-duty steel block extensions, to help protect building and dock from damage

### Operation

- Easy to deploy, less effort "operator maintains balanced control"
- Working range capability of 5" above and 5" below dock level
- Self-storing upon truck departure

### Ease of service

- Comfort grip handle has secondary use as maintenance stand
- Grease fittings on 25,000 lb and 30,000 lb capacities to minimize operational friction.
- Field adjustability for kicker bar and spring tension

### Associated products

- Vehicle restraint systems
- Light communication systems
- Wheel chocks

To meet OSHA and ANSI requirements and to minimize legal/insurance issues, the use of wheel chocks (at a minimum) is mandatory anytime equipment is used at the dock to load/unload vehicles. However, with the high lifetime cost of wheel chocks and their limited effectiveness, we recommend the combined use of vehicle restraints and wheel chocks as the accepted method of securing trucks to the dock. I.V. DOCK-RAMP provides leading technology in manual and/or power activated vehicle restraints. Maximize your employee safety while providing your company a modern, safe loading dock area.

The MED Series edge-of-dock leveler from DOCK-RAMP is ideally suited for applications where installation of pit levelers is not feasible or where standard fleet bed heights are serviced at the loading dock. The MED Series is easily installed to the dock face providing an efficient self storing docking unit, replacing cumbersome dock plates.



Stored traffic position



Insert comfort grip handle



Pull back



Push forward

# MED SERIES

## MECHANICAL EDGE-OF-DOCK

Mechanical edge-of-dock shall be Model \_\_\_\_\_, unit nominal size to be \_\_\_\_\_ wide x \_\_\_\_\_ long, as provided by I.V. Dock-Ramp, Montréal, Qc. H8T 1A1.

### Standard construction features

- 15" lip with bevel edge
- Hole in lip to help with easy handling and installation
- Welding procedure compliant with A.W.S.D. 1. 98
- Deck and lip constructed out of high tensile steel
- Four way diamond tread plate
- Two (2) molded rubber dock bumpers 10"W x 13"H x 4"D mounted to heavy-duty bumper blocks

### Mechanical operating system

- Provides quiet, dependable and smooth cycling.
1. Insert the operating handle into deck side pocket.
  2. Pull the comfort handle back; the spring-assisted deck raises to a vertical position.
  3. Pushing the handle forward lowers the deck, and lip automatically extends onto trailer.

### Lip operation

Lip automatically extends as unit is lowered onto truck bed and returns to stored position upon truck departure. The length of the lip shall not be less than 15".

### Automatic vertical compensation and travel

Unit provides float up to 5" above and below dock level.

### Automatic lateral compensation

Leveler shall have deck flex to compensate for canted (out of level) truck beds

### Rated capacity

- 20,000 lbs.  25,000 lbs.  30,000 lbs.

### Options

- 17" lip  Flat lip

### Serviceability

- Comfort grip handle has secondary use as maintenance stand
- Grease fittings provided on 25,000 lb and 30,000 lb units
- Field adjustability for kicker bar and spring tension

### Finish and color

- Unit to be painted gray

Manufactured Exclusively for:

**Équipement I V Equipment**

Inc.

Montréal, Qc. H8T 1A1

Téléphone: 800-867-6515 - Télécopieur: 514-631-3253

www.ivdock-ramp.ca

MODEL	CAPACITY	DECK SIZE (W x L)
<input type="checkbox"/> MED66	<input type="checkbox"/> 20,000 lb	66" x 27"
<input type="checkbox"/> MED72	<input type="checkbox"/> 25,000 lb <input type="checkbox"/> 30,000 lb	72" x 27"
<input type="checkbox"/> MED78	<input type="checkbox"/> 25,000 lb	78" x 27"

For metric conversion to mm, multiply inches by 25.4.  
For conversion to kg, divide lb by 2.2.

### Warranty

Standard one-year parts and labor warranty from date of shipment. Warranties are subject to standard limitations on liability. Please consult I.V. DOCK-RAMP warranties at <http://www.ivdock-ramp.ca> for full details on warranty information and product registration.

### Installation accessories

- Approach ramps
- Face plates
- 8" Pour-in channel

### Optional products

- Vehicle restraint systems
- Communication systems
- Wheel chock systems

### Nominal dimensions

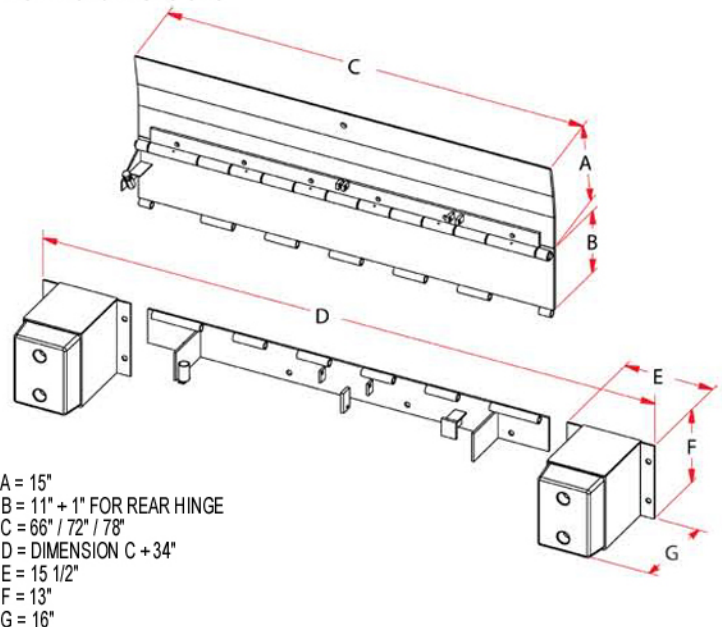

- Note:**
1. Recommend minimum 8" structural concrete embedment (pour-in) channel, installed by others. Some components are not illustrated. Mounting anchors are not included.
  2. Working range reduced by 2" when ordered with 17" lip and/or flat lip option.

**AUTHORIZED  
DEALER**